

**NOTES**

1. Airline piping to FAST® may not exceed 100 FT [30m] total length and have a maximum of 4 elbows in the piping system. For distances greater than 100 FT [30m] consult factory. Blower must be located above flood levels on a concrete base 26" X 20" X 2" [65 X 50 X 5cm] min.
2. Vent to desired location and cover opening with a vent grate with at least 7 sq in. [45 sq. cm] open surface area. Secure with stainless steel screws. Vent piping must not allow condensate build up or create back pressure. Vent must be above finished grade or higher (see sheet 4 of 4).
3. All appurtenances to FAST® (e.g. tanks, access ports, electrical, etc.) must conform to all applicable country, state, province, and local plumbing and electrical codes. Pump out access shall be adequate to thoroughly clean out both zones.
4. All inspection, viewing and pump out ports must be secured to prevent accidental or unauthorized access.
5. Tank, piping, conduit, etc. are provided by others. Blower control system by Bio-Microbics, Inc. See Installation Manual.
6. If less than the specified minimums are considered necessary, consult factory for guidance.
7. All piping and ancillary equipment installed after FAST must not impede or restrict free flow of effluent.
8. The NitriFAST is designed to receive treated effluent from an approved secondary treatment system.
9. The air supply line into the FAST® unit must be secured to prevent vibration induced damage. The air supply line should be secured with a non-corrosive clamp every 2' min [60 cm]. See alternate air supply option on sheet 4 of 4.
10. Specialized treatment levels may require specific features to be incorporated into the design. Consult factory for guidance.
11. Min. height may be reduced, consult factor and reference "Low Profile Module Procedure.pdf"
12. Refer to sheet 4 of 4 for leg extensions requirements.

DO NOT SCALE  
UNLESS NOTED  
DIMENSIONS  
ARE IN INCHES  
[CENTIMETERS]  
TOLERANCES  
± 0.02 IN/IN  
[± 0.05 CM/CM]



NitriFAST 0.9 FAST Unit

WEIGHT		lb	SIZE	DRAWING NUMBER		SHEET
NAME	DATE			A		
DRAWN	CTC	12/18/2006	NitriFAST® 0.9 with feet			
CHECKED	PF	10/10/2013	REVISED 10/10/2013		REV. INI-03-R	

THE INFORMATION CONTAINED IN THIS DRAWING IS THE SOLE PROPERTY OF BIO-MICROBICS INC. ANY REPRODUCTION IN PART OR AS A WHOLE WITHOUT THE WRITTEN PERMISSION OF BIO-MICROBICS INC. IS PROHIBITED. DESIGN AND INVENTION RIGHTS ARE RESERVED. IN THE INTEREST OF TECHNOLOGICAL ADVANCEMENT, ALL PRODUCTS ARE SUBJECT TO DESIGN AND OR MATERIAL CHANGE WITHOUT NOTICE.

BIO-MICROBICS © 2014

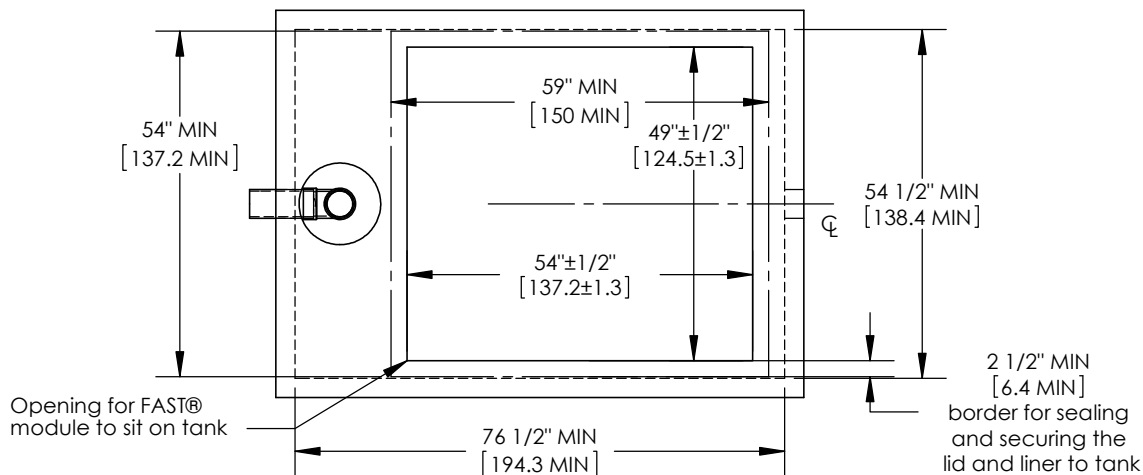
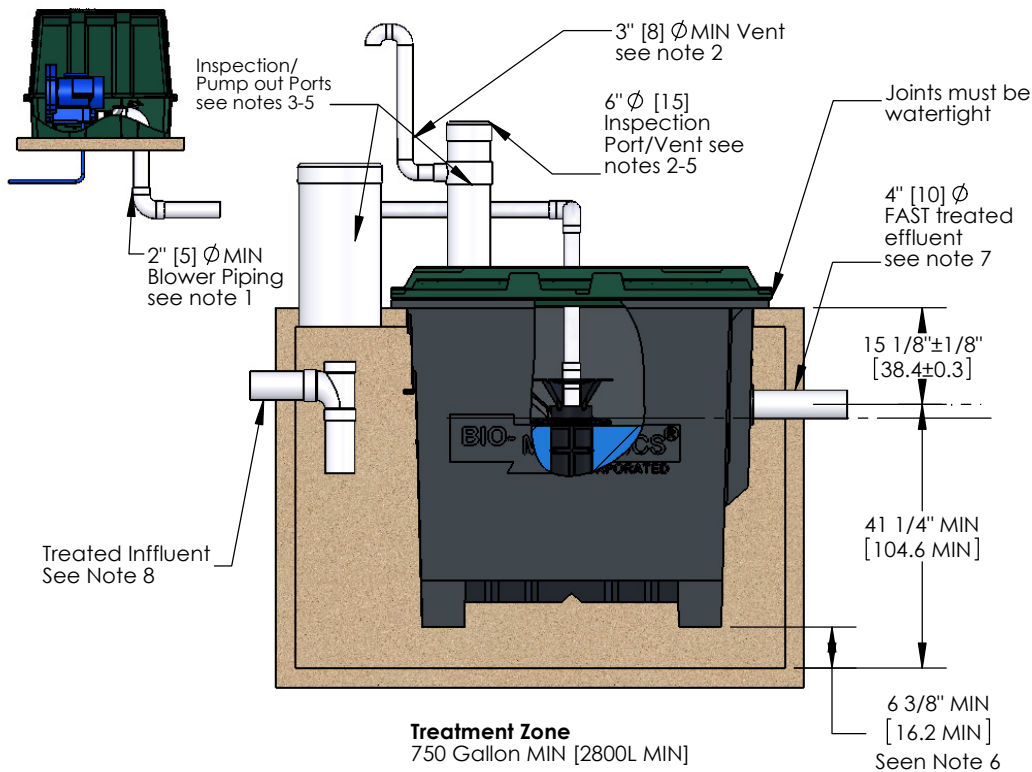

**NOTES**

1. Airline piping to FAST® may not exceed 100 FT [30m] total length and have a maximum of 4 elbows in the piping system. For distances greater than 100 FT [30m] consult factory. Blower must be located above flood levels on a concrete base 26" X 20" X 2" [65 X 50 X 5cm] min.
2. Vent to desired location and cover opening with a vent grate with at least 7 sq in. [45 sq. cm] open surface area. Secure with stainless steel screws. Vent piping must not allow condensate build up or create back pressure. Vent must be above finished grade or higher (see sheet 4 of 4).
3. All appurtenances to FAST® (e.g. tanks, access ports, electrical, etc.) must conform to all applicable country, state, province, and local plumbing and electrical codes. Pump out access shall be adequate to thoroughly clean out both zones.
4. All inspection, viewing and pump out ports must be secured to prevent accidental or unauthorized access.
5. Tank, piping, conduit, etc. are provided by others. Blower control system by Bio-Microbics, Inc. See Installation Manual.
6. If less than the specified minimums are considered necessary, consult factory for guidance.
7. All piping and ancillary equipment installed after FAST must not impede or restrict free flow of effluent.
8. The NitriFAST is designed to receive treated effluent from an approved secondary treatment system.
9. Installations using a FAST® system lid are capable of withstanding AASHTO H-10 equivalent loads. Any installation in which a FAST lid is buried deeper than 3 feet, or where additional loading conditions may occur, a professional engineer should be consulted. FAST® with feet option should be considered. Refer to Installation Manual for more details.
10. Specialized treatment levels may require specific features to be incorporated into the design. Consult factory for guidance.

DO NOT SCALE		 BETTER WATER. BETTER WORLD.®		NitriFAST 0.9 FAST Unit	
UNLESS NOTED DIMENSIONS ARE IN INCHES [CENTIMETERS] TOLERANCES ± 0.02 IN/IN [± 0.05 CM/CM]					
WEIGHT	lb	SIZE	DRAWING NUMBER		
		A	NitriFAST® 0.9 with lid		
DRAWN	CTC	12/18/2006	SHEET 2 OF 4		
CHECKED	PF	10/10/2013	REVISED 10/10/2013	REV. INI-03-R	

THE INFORMATION CONTAINED IN THIS DRAWING IS THE SOLE PROPERTY OF BIO-MICROBICS INC. ANY REPRODUCTION IN PART OR AS A WHOLE WITHOUT THE WRITTEN PERMISSION OF BIO-MICROBICS INC. IS PROHIBITED. DESIGN AND INVENTION RIGHTS ARE RESERVED. IN THE INTEREST OF TECHNOLOGICAL ADVANCEMENT, ALL PRODUCTS ARE SUBJECT TO DESIGN AND OR MATERIAL CHANGE WITHOUT NOTICE.

BIO-MICROBICS © 2014

Specifications for NitrifAST 0.9 Wastewater Nitrification System

1. GENERAL

The contractor shall furnish and install (1) NitrifAST 0.9 nitrification system as manufactured by Bio-Microbics, Inc. The treatment system shall be complete with all needed equipment as shown on the drawings and specified herein.

The principal items of equipment shall include FAST® system insert, leg extensions, or lid, blower assembly, blower controls and alarms. All other items will be provided by others. The NitrifAST 1.0 unit shall be situated within a 750 Gallon[2800L] minimum compartment as shown on the drawings. Tank must provide adequate pump out access and conform to local, state, and all other applicable codes. The contractor shall coordinate the proper fabrication of the tank between the tank and FAST system suppliers as well as the installation of the FAST unit, and delivery to the job site.

2. OPERATING CONDITIONS

The NitrifAST 0.9 nitrification system shall be capable of nitrifying wastewater that has been treated to secondary levels not to exceed 900 US Gallons per day (3400LPD) provided the waste contains nothing that will interfere with biological treatment. The FAST system is a biological treatment system not meant for non-biodegradable or industrial wastewater. Consult factory for proper sizing and usage.

3. MEDIA

The FAST media shall be manufactured of rigid PVC, polyethylene, or polypropylene and it shall be supported by the polyethylene insert. The media shall be fixed in position and contain no moving or wearing parts and shall not corrode. The media shall be designed and installed to ensure that sloughed solids descend through the media to the bottom of the septic tank.

4. BLOWER

The NitrifAST 0.9 unit shall come equipped with a regenerative type blower capable of delivering 17-25 CFM [31-46m3/hr]. The blower assembly shall include an inlet filter with metal filter element. The blower shall be mounted outside the tank on a contractor supplied concrete base. Blower piping to the tank shall use non-corrosive material (PVC, Galvanized, or Stainless Steel). Do not run galvanized pipe inside the treatment tank. Refer to Installation Manual for further details.

5. REMOTE MOUNTED BLOWER

The blower must not set in standing water and its elevation must be higher than the normal flood level. A two-piece, rectangular housing shall be provided. The discharge air line from the blower to the NitrifAST System, shall be provided and installed by the contractor.

6. ELECTRICAL

The electrical source should be within 150 feet [45 meters] of the blower, consult local codes for longer wiring distances. All wiring must conform to all applicable codes(IEC, NEC, etc.). Wiring distances must prevent significant voltage loss. Input power on 60Hz electrical systems 110/220VAC, 1Ø, 3.5/1.7 FLA, on 50 Hz electrical systems 220VAC, 1Ø, 1.9 FLA. Other voltages and phase are also available. Actual power consumption varies with site conditions. All conduit and wiring shall be supplied by contractor.

7. CONTROLS

The control panel provides power to the blower with an alarm system consisting of a visual and audible alarm capable of signaling blower circuit failure and high water conditions. The control panel is equipped with SFR® (Sequencing Fixed Reactor) timed control feature. A manual silence button is included.

8. INSTALLATION AND OPERATING INSTRUCTIONS

All work must be done in accordance with local codes and regulations. Installation of the FAST 0.9 shall be done in accordance with the written instructions provided by the manufacturer. Manuals shall be furnished, which will include a description of system installation, operation, and maintenance procedures.

9. FLOW AND DOSING

FAST systems have been successfully designed, tested and certified receiving gravity, demand-based influent flow. When influent flow is controlled by pump or other means to help with highly variable flow conditions, then multiple dosing events should be used to maximize performance. The flow rate shall not exceed 5 gpm (19 Lpm) with a maximum hourly flow not to exceed 10% of the design daily flow (90 gph (340 LPH)).

10. WARRANTY

Bio-Microbics, Inc. warrants all new residential FAST ® models (NitrifAST® 0.5, 0.625, 0.75, 0.9, 1.5, 3.0, 4.5 and 9.0) against defects in materials and workmanship for a period of one year after installation or eighteen months from date of shipment, whichever occurs first. All are subject to the following terms and conditions below:

During the warranty period, if any part is defective or fails to perform as specified when operating at design conditions, and if the equipment has been installed and is being operated and maintained in accordance with the written instructions provided by Bio-Microbics, Inc., Bio-Microbics, Inc. will repair or replace at its discretion such defective parts free of charge. Defective parts must be returned by owner to Bio-Microbics, Inc.'s factory postage paid, if so requested. The cost of labor and all other expenses resulting from replacement of the defective parts and from installation of parts furnished under this warranty and regular maintenance items such as filters or bulbs shall be borne by the owner. This warranty does not cover general system misuse, aerator components which have been damaged by flooding or any components that have been disassembled by unauthorized persons, improperly installed or damaged due to altered or improper wiring or overload protection. This warranty applies only to the treatment plant and does not include any of the structure wiring, plumbing, drainage, septic tank or disposal system. Bio-Microbics, Inc. reserves the right to revise, change or modify the construction and/or design of the FAST system, or any component part or parts thereof, without incurring any obligation to make such changes or modifications in present equipment. Bio-Microbics, Inc. is not responsible for consequential or incidental damages of any nature resulting from such things as, but not limited to, defect in design, material, or workmanship, or delays in delivery, replacements or repairs.

THIS WARRANTY IS IN LIEU OF ALL OTHER WARRANTIES EXPRESS OR IMPLIED. BIO-MICROBICS SPECIFICALLY DISCLAIMS ANY IMPLIED WARRANTY OF MERCHANTABILITY OR FITNESS FOR A PARTICULAR PURPOSE. NO REPRESENTATIVE OR PERSON IS AUTHORIZED TO GIVE ANY OTHER WARRANTY OR TO ASSUME FOR BIO-MICROBICS, INC., ANY OTHER LIABILITY IN CONNECTION WITH THE SALE OF ITS PRODUCTS. Contact your local distributor for parts and service.

<p><b>DO NOT SCALE</b></p> <p>UNLESS NOTED DIMENSIONS ARE IN INCHES [CENTIMETERS] TOLERANCES ± 0.02 IN/IN [± 0.05 CM/CM]</p>		 <p>BETTER WATER. BETTER WORLD.®</p> <p>NitrifAST 0.9 FAST Unit</p>	
<p>THE INFORMATION CONTAINED IN THIS DRAWING IS THE SOLE PROPERTY OF BIO-MICROBICS INC. ANY REPRODUCTION IN PART OR AS A WHOLE WITHOUT THE WRITTEN PERMISSION OF BIO-MICROBICS INC. IS PROHIBITED. DESIGN AND INVENTION RIGHTS ARE RESERVED. IN THE INTEREST OF TECHNOLOGICAL ADVANCEMENT, ALL PRODUCTS ARE SUBJECT TO DESIGN AND OR MATERIAL CHANGE WITHOUT NOTICE.</p>			
<p>BIO-MICROBICS © 2014</p>		<p>SHEET 3 OF 4</p>	

Minimum leg extension assembly  
see note 1-4

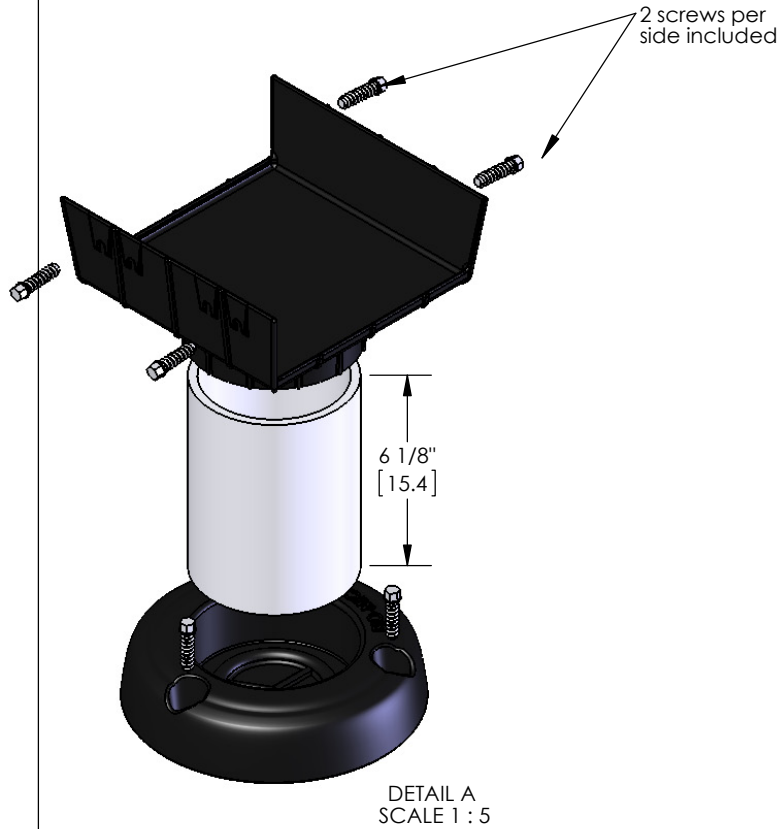

**FAST® Lid Vent Option**

NDS 6" Grate MIN 7 SQ in  
[45 SQ cm] of open  
surface area

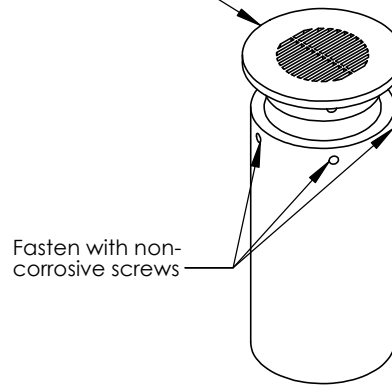

DETAIL B  
SCALE 1 : 4

**Alternate Air Supply  
Option**

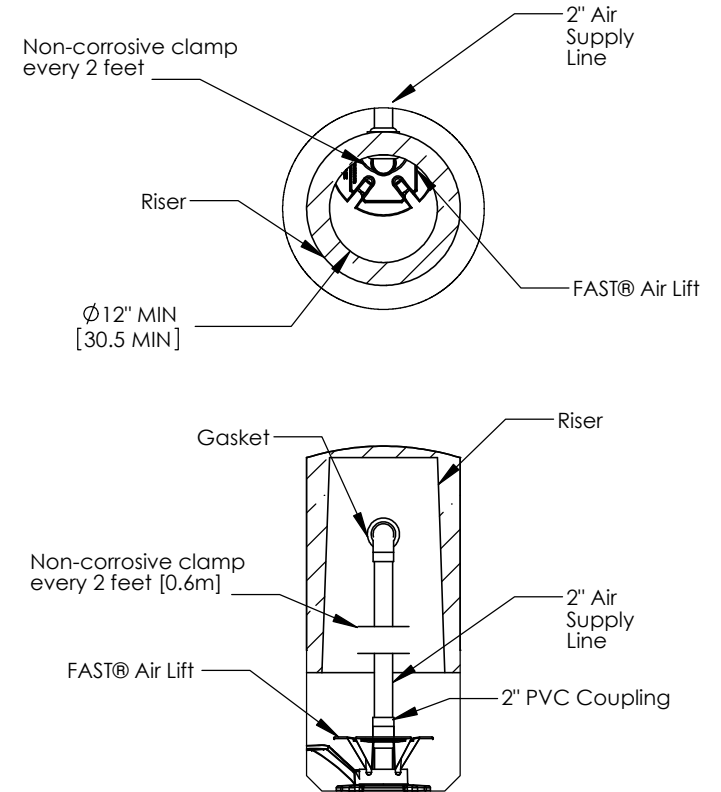

**Notes**

1. Secure leg extension to the FAST® unit by placing two screws on each side of the leg extension (4 screws per foot are included).
2. Cut 4" schd. 40 PVC pipe (not included) to obtain the desired height. Minimum pipe length of 6 1/8" [15.56cm] will provide minimum clearance of 6 3/8 inches [16.2 cm]. For heights greater than 18" [45.7cm] use schd. 80 PVC pipe (not included). Consult factory for extending leg beyond 36" [90cm].
3. Anchor the leg extensions to the tank with non-corrosive hardware (not included) at the provided mounting points .
4. If less than the specified minimums are considered necessary, consult factory for guidance.
5. The air supply line into the FAST® unit must be secured to prevent vibration induced damage. The air supply line should be secured with a non-corrosive clamp every 2ft [0.6m] minimum.
6. Tank, anchors, piping conduit, blower, housing pad and vents are provided by others.

DO NOT SCALE  
UNLESS NOTED  
DIMENSIONS  
ARE IN INCHES  
[CENTIMETERS]  
TOLERANCES  
± 0.02 IN/IN  
[± 0.05 CM/CM]



NitriFAST 0.9 FAST Unit

THE INFORMATION CONTAINED IN THIS DRAWING IS THE SOLE PROPERTY OF BIO-MICROBICS INC. ANY REPRODUCTION IN PART OR AS A WHOLE WITHOUT THE WRITTEN PERMISSION OF BIO-MICROBICS INC. IS PROHIBITED. DESIGN AND INVENTION RIGHTS ARE RESERVED. IN THE INTEREST OF TECHNOLOGICAL ADVANCEMENT, ALL PRODUCTS ARE SUBJECT TO DESIGN AND OR MATERIAL CHANGE WITHOUT NOTICE.

BIO-MICROBICS © 2014

WEIGHT	lb	SIZE	DRAWING NUMBER	SHEET 4 OF 4
NAME	DATE	A	NitriFAST® 0.9 Details	
DRAWN	CTC	12/18/2006		
CHECKED	PF	10/10/2013	REVISED 10/10/2013 REV. INI-07-M	