

- NOTES**
- Blower piping to BioBarrier® HSMBR® may not exceed 40 FT [12 m] total length and use 4 elbows maximum per train. For distances greater than 40 FT [12 m] - consult factory. Blowers must be located above flood/standing water levels on concrete bases 42" X 28" X 2" [105 X 70 X 5cm] minimum.
 - Run vent(s) to desired location above finish grade and cover opening(s) with vent grate(s) w/at least a total of 25 sq in. [161 sq. cm] of total open surface area. Secure with stainless steel screws. Vent piping must not allow excess moisture build up or back pressure.
 - All appurtenances to BioBarrier® (e.g. tank pump outs, etc.) must conform to all country, state, province, and local plumbing and electrical codes.
 - The BioBarrier® HSMBR® control systems are provided by Bio-Microbics, Inc.
 - The primary compartments may be a separate tank.
 - The baffle separating the settling and the treatment chambers shall be sealed to the top of the tank, as shown on the drawing. Ventilation for the settling zone shall be provided for in the same manner as a traditional septic tank.
 - All inspection, viewing, access, and pump out ports must be secured, to prevent accidental or unauthorized access.
 - Tank, anchors, piping, conduit, blower housing pads and vents are provided by others.
 - All piping and ancillary equipment installed after BioBarrier® HSMBR®, must not impede or restrict filtrate pump.
 - BioBarrier® HSMBR® assemblies must be secured to the tanks to prevent movement or floatation(see Installation Instructions for details).
 - Distribution box must balance flow to both trains.
 - Filtrate pump vault must remain dry.

DO NOT SCALE
UNLESS NOTED
DIMENSIONS
ARE IN INCHES
[CENTIMETERS]
TOLERANCES
± 0.02 IN/IN
[± 0.05 CM/CM]



HSMBR 4.5

WEIGHT		lb	SIZE	DRAWING NUMBER		SHEET 1 OF 6
NAME	DATE		A	HSMBR® 4.5-D		
DRAWN	CTC	11/25/2009				
CHECKED	PF	10/12/2015		REVISED 10/12/2015	REV. INI-04-Z	

THE INFORMATION CONTAINED IN THIS DRAWING IS THE SOLE PROPERTY OF BIO-MICROBICS INC. ANY REPRODUCTION IN PART OR AS A WHOLE WITHOUT THE WRITTEN PERMISSION OF BIO-MICROBICS INC. IS PROHIBITED. DESIGN AND INVENTION RIGHTS ARE RESERVED. IN THE INTEREST OF TECHNOLOGICAL ADVANCEMENT, ALL PRODUCTS ARE SUBJECT TO DESIGN AND OR MATERIAL CHANGE WITHOUT NOTICE.

BIO-MICROBICS © 2016

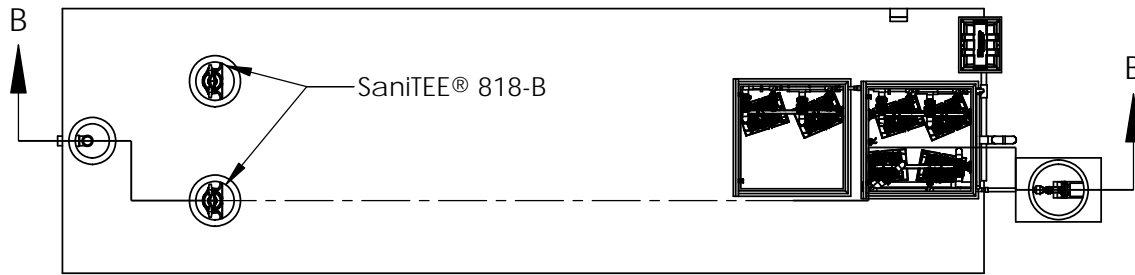

NOTES

1. Blower piping to BioBarrier® HSMBR® may not exceed 40 FT [12 m] total length and use 4 elbows maximum per train. For distances greater than 40 FT [12 m] - consult factory. Blowers must be located above flood/standing water levels on concrete bases 58" X 36" X 2" [150 X 90 X 5cm] minimum.
2. Run vent(s) to desired location above finish grade and cover opening(s) with vent grate(s) w/at least 25 sq in. [161 sq. cm] of total open surface area. Secure with stainless steel screws. Vent piping must not allow excess moisture build up or back pressure.
3. All appurtenances to BioBarrier® (e.g. tank pump outs, etc.) must conform to all country, state, province, and local plumbing and electrical codes.
4. The BioBarrier® HSMBR® control systems are provided by Bio-Microbics, Inc.
5. The primary compartments may be a separate tank.
6. The baffle separating the settling and the treatment chambers shall be sealed to the top of the tank, as shown on the drawing. Ventilation for the settling zone shall be provided for in the same manner as a traditional septic tank.
7. All inspection, viewing, access, and pump out ports must be secured, to prevent accidental or unauthorized access.
8. Tank, anchors, piping, conduit, blower housing pads and vents are provided by others.
9. All piping and ancillary equipment installed after BioBarrier® HSMBR®, must not impede or restrict filtrate pump.
10. BioBarrier® HSMBR® assemblies must be secured to the tanks to prevent movement or floatation(see Installation Instructions for details).
11. Filtrate pump vault must remain dry.

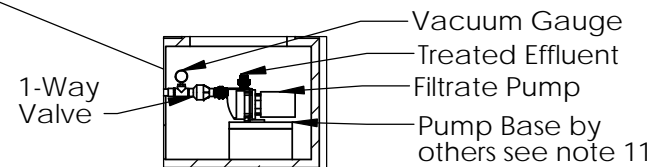
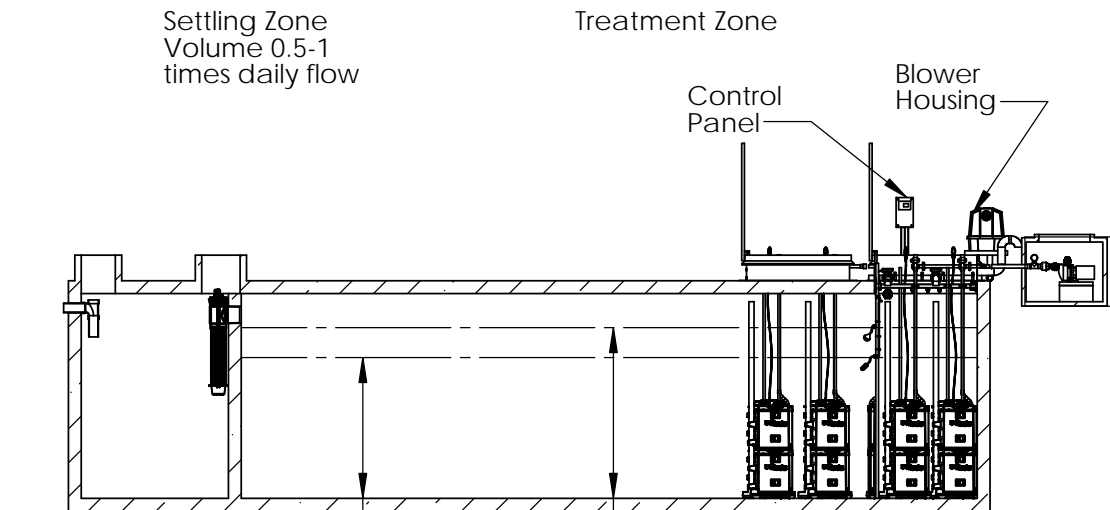

Operating Water Level
[168]
66

Maximum Water Level
[203 MAX]
80 MAX

SECTION B-B

DO NOT SCALE
UNLESS NOTED
DIMENSIONS
ARE IN INCHES
[CENTIMETERS]
TOLERANCES
± 0.02 IN/IN
[± 0.05 CM/CM]



HSMBR 4.5

THE INFORMATION CONTAINED IN THIS DRAWING IS THE SOLE PROPERTY OF BIO-MICROBICS INC. ANY REPRODUCTION IN PART OR AS A WHOLE WITHOUT THE WRITTEN PERMISSION OF BIO-MICROBICS INC. IS PROHIBITED. DESIGN AND INVENTION RIGHTS ARE RESERVED. IN THE INTEREST OF TECHNOLOGICAL ADVANCEMENT, ALL PRODUCTS ARE SUBJECT TO DESIGN AND OR MATERIAL CHANGE WITHOUT NOTICE.

BIO-MICROBICS © 2016

WEIGHT		lb	SIZE	DRAWING NUMBER		SHEET 2 OF 6
NAME	DATE		A	HSMBR® 4.5-S		
DRAWN	CTC	11/25/2009		REVISED 10/12/2015		
CHECKED	PF	10/12/2015		REV. INI-05-N		

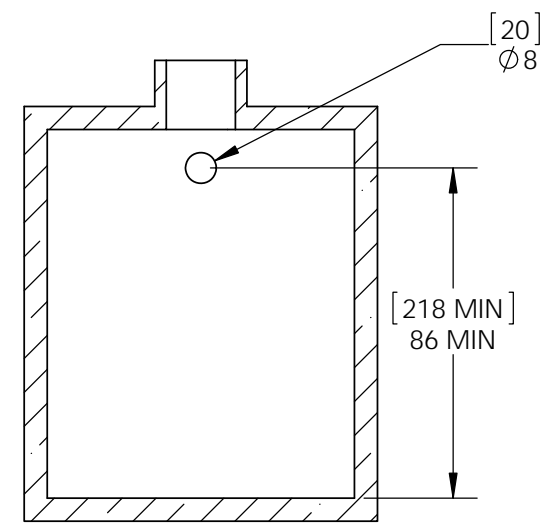
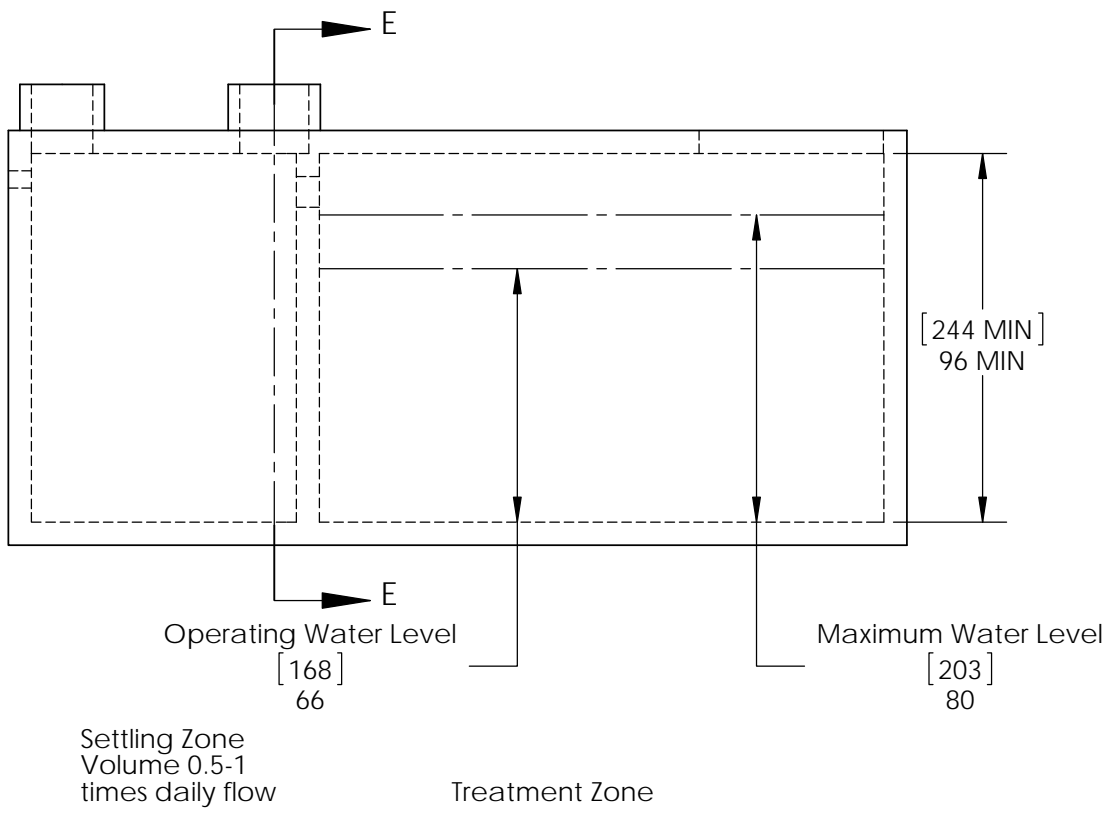

SECTION E-E
SCALE 1 : 50

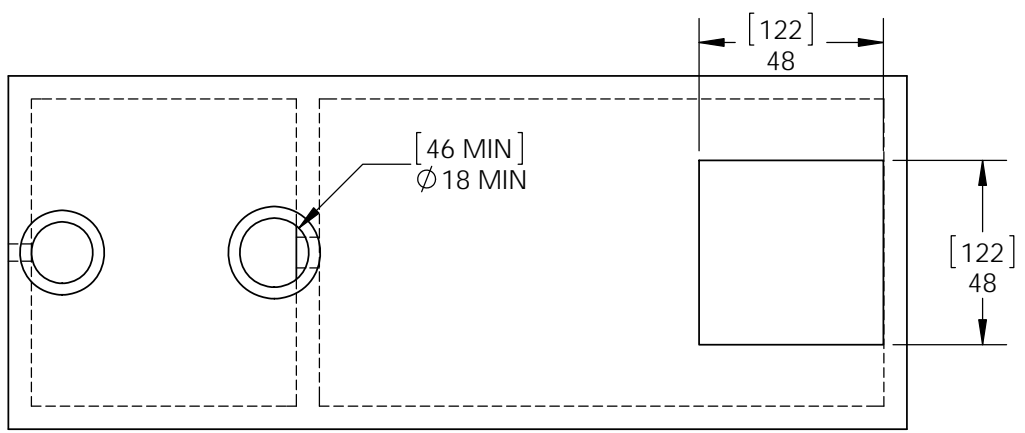

NOTES:
Consult factory for tank volume sizing.

DO NOT SCALE
UNLESS NOTED
DIMENSIONS
ARE IN INCHES
[CENTIMETERS]
TOLERANCES
 ± 0.02 IN/IN
 $[\pm 0.05$ CM/CM]



HSMBR 4.5

THE INFORMATION CONTAINED IN THIS DRAWING IS THE SOLE PROPERTY OF BIO-MICROBICS INC. ANY REPRODUCTION IN PART OR AS A WHOLE WITHOUT THE WRITTEN PERMISSION OF BIO-MICROBICS INC. IS PROHIBITED. DESIGN AND INVENTION RIGHTS ARE RESERVED. IN THE INTEREST OF TECHNOLOGICAL ADVANCEMENT, ALL PRODUCTS ARE SUBJECT TO DESIGN AND OR MATERIAL CHANGE WITHOUT NOTICE.

BIO-MICROBICS © 2016

WEIGHT	lb	SIZE	DRAWING NUMBER	Tank Details HSMBR 4.5-D	SHEET 3 OF 6
NAME	DATE				
DRAWN	CTC	11/25/2009			
CHECKED	PF	10/12/2015	REVISED 10/12/2015	REV. INI-04-Y	

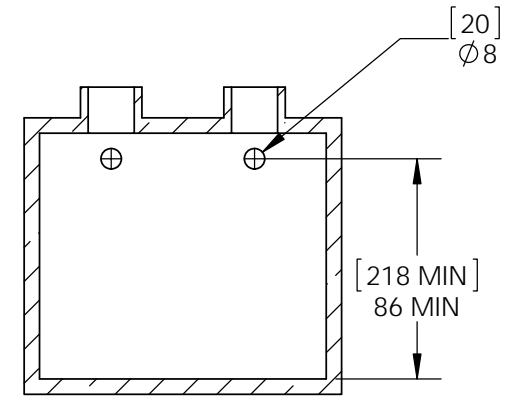
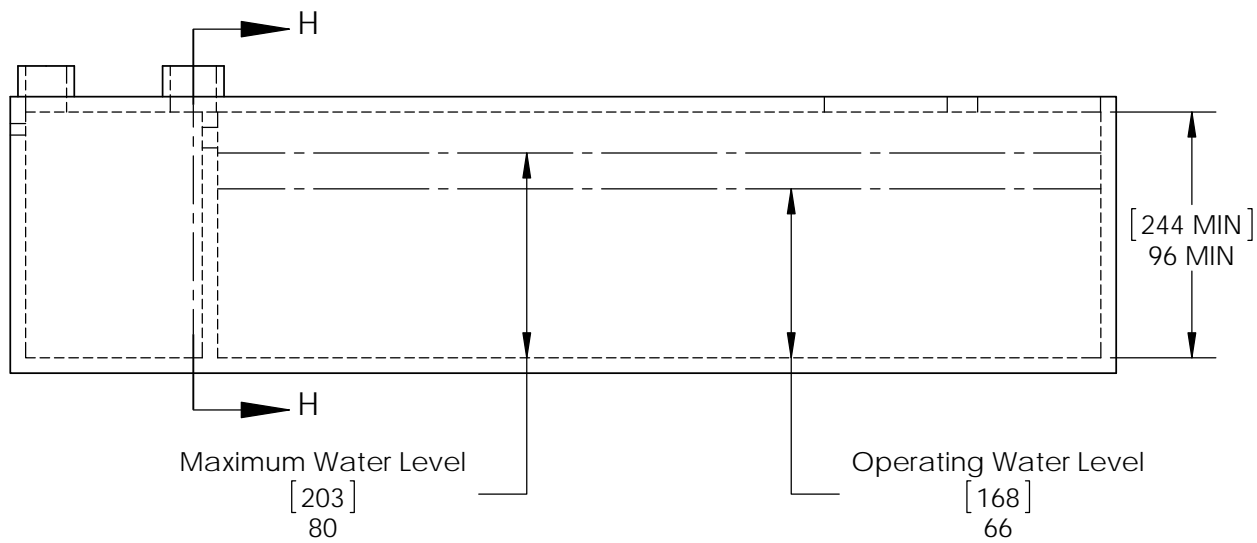

SECTION H-H
SCALE 1 : 75

Settling Zone
Volume 0.5-1
times daily flow

Treatment Zone

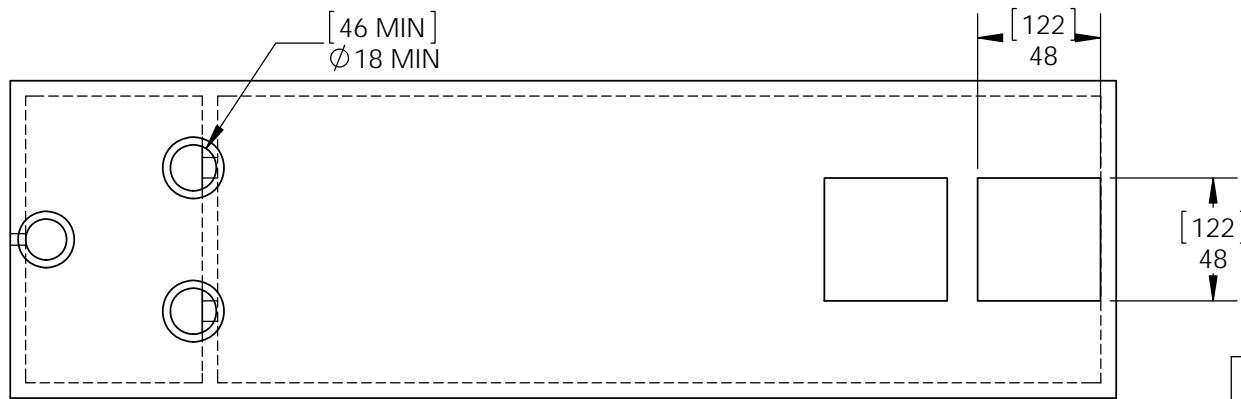

NOTES:
Consult factory for tank volume sizing.

DO NOT SCALE		 BETTER WATER. BETTER WORLD. [®]		HSMBR 4.5	
UNLESS NOTED DIMENSIONS ARE IN INCHES [CENTIMETERS] TOLERANCES ± 0.02 IN/IN [± 0.05 CM/CM]					
WEIGHT	lb	SIZE	DRAWING NUMBER		
		A	Tank Details HSMBR4.5-S		
DRAWN	CTC	DATE	11/25/2009		
CHECKED	PF	DATE	10/12/2015		
			REVISED	10/12/2015	REV. INI-04-Y

THE INFORMATION CONTAINED IN THIS DRAWING IS THE SOLE PROPERTY OF BIO-MICROBICS INC. ANY REPRODUCTION IN PART OR AS A WHOLE WITHOUT THE WRITTEN PERMISSION OF BIO-MICROBICS INC. IS PROHIBITED. DESIGN AND INVENTION RIGHTS ARE RESERVED. IN THE INTEREST OF TECHNOLOGICAL ADVANCEMENT, ALL PRODUCTS ARE SUBJECT TO DESIGN AND OR MATERIAL CHANGE WITHOUT NOTICE.

BIO-MICROBICS © 2016

SHEET
4 OF 6

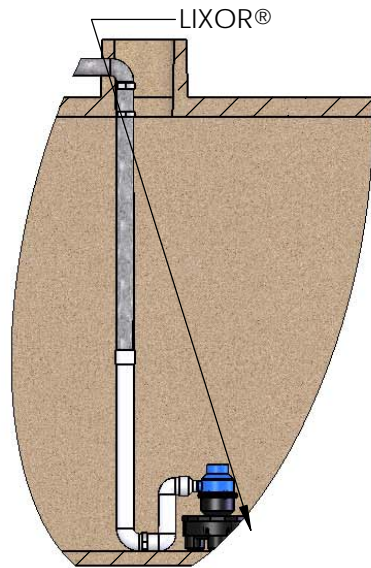

Supplemental Air

see note 4,5, & 6

independent float stand supplied by others

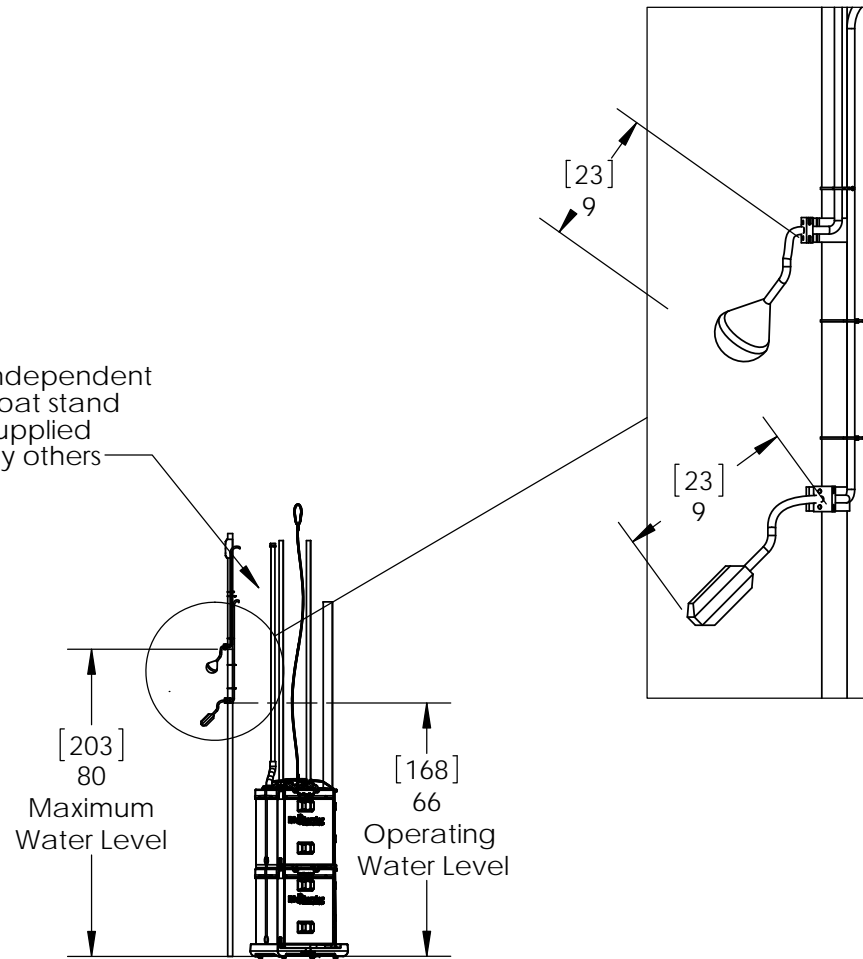

Notes:

1. Filtrate Pump must be secured in a dry vault and not be exposed to freezing temperatures.
2. Float stand should be located away from the MBR modules within the treatment zone to prevent float chatter.
3. Utilize SS lifting cable to remove the MBR module.
4. Supplemental aeration with LIXOR® will be required for wastewater with higher than 300mg/L BOD.
5. See LIXOR® Drawings for more details.
6. Provide additional ventilation as required per LIXOR specifications.

DO NOT SCALE
UNLESS NOTED
DIMENSIONS
ARE IN INCHES
[CENTIMETERS]
TOLERANCES
± 0.02 IN/IN
[± 0.05 CM/CM]



HSMBR 4.5

WEIGHT		lb	SIZE	DRAWING NUMBER		SHEET 5 OF 6
NAME	DATE	A	HSMBR® Details			
DRAWN	CTC	11/25/2009	REVISED 10/12/2015			
CHECKED	PF	10/12/2015	REV. INI-05-N			

Specifications for BioBarrier® HSMBR® 4.5 Wastewater Treatment System

1. GENERAL

The contractor shall furnish and install (1) BioBarrier® HSMBR® 4.5 treatment system as manufactured by Bio-Microbics, Inc. The treatment system shall be complete with all needed equipment as shown on the drawings and specified herein. The principal items of equipment supplied by Bio-Microbics, Inc. shall include BioBarrier® HSMBR® assemblies, all controls, filtrate pumps, air blower assemblies, and SanITEE® 818-B pre-screen devices. All other items will be provided by others. The BioBarrier® HSMBR 4.5-D system shall be installed in two (2) identical treatment trains. Each treatment train shall include three (3) BioBarrier® assemblies situated within a two-compartment tank with a minimum wall height of 8 feet. The BioBarrier® HSMBR 4.5-S system shall be installed in one treatment train. The treatment train shall include six (6) BioBarrier® assemblies situated within a two-compartment tank with a minimum wall height of 8 feet. Suggested maximum settling zone is (1) X the daily flow. Tank(s) must provide adequate pump out access and conform to local, state, and all other applicable codes. The contractor shall provide coordination with tank supplier with regards to fabrication of the tank, installation of the BioBarrier® unit and delivery to the job site.

2. OPERATING CONDITIONS

The BioBarrier® HSMBR® 4.5 treatment system shall be capable of treating up to 4,500 gpd wastewater from all facilities producing appropriate waste to develop and sustain a viable biomass. Waste containing inhibitory substances for the biological processes or membrane filtration operation is not recommended for treatment in the BioBarrier® HSMBR® system. Consult factory for proper sizing and usage.

3. MEMBRANE

The membrane is a combination of ultrafiltration and microfiltration using PVdF and PES cast material. The membrane sheet is supported by HDPE or ABS and laser welded to the plate. The BioBarrier® HSMBR® membrane module shall consist of flat sheet membranes arranged in a cartridge which is aerated via subhousing air grid. The BioBarrier® HSMBR® membrane assembly shall be fixed in position and shall use non corrosive parts. Each membrane system shall be designed and installed to ensure that adequate turbulence is provided by the aeration system to insure easy movement of MLSS within the membrane system.

4. BLOWERS

The BioBarrier® HSMBR® 4.5-D system shall come equipped with two (2) blowers each capable of delivering 30 - 45 CFM [50-75 m3/hr]. The blower assemblies shall include an inlet filter with metal filter element. The BioBarrier® HSMBR® 4.5-S system shall come equipped with a blower capable of delivering 60 - 90 CFM [105-155 m3/hr]. The blower assemblies shall include an inlet filter with metal filter element. Blowers shall be mounted, up to 40 feet [12 meters] maximum, and no more than 4 elbows from the BioBarrier® HSMBR® assembly on a contractor supplied concrete base. Blowers must not set in standing water and their elevation must be higher than the normal flood level. A two-piece, rectangular housing shall be provided for each blower. The discharge air line from each blower to the BioBarrier® HSMBR® assembly shall be provided and installed by the contractor.

5. FILTRATE PUMP

Pumps shall be mounted, up to 20 feet (6 meters) maximum from the BioBarrier® HSMBR® tank in a contractor supplied pump chamber. Pumps must not set in standing water and their elevation must be higher than normal flood level. The suction and discharge lines as well as the vacuum gauge and the one-way valve for each pump shall be provided and installed by the contractor. The filtrate pump is not intended as dosing pump for final disposal of the effluent.

6. ELECTRICAL

The electrical source should be within 150 feet [45.7 meters] of the blower consult local codes for longer wiring distances. All wiring must conform to all applicable codes (IEC, NEC, etc.). Wiring distances must prevent significant voltage loss. Input power on 60Hz electrical system is three phase, 208-230 VAC, maximum 20 Amps. Input power on 50Hz electrical system is three phase, 208-230 VAC, maximum 20 Amps. All conduit and wiring shall be supplied by contractor.

7. CONTROLS

The BioBarrier® HSMBR® 4.5-D system shall come equipped with two (2) control panels. The BioBarrier® HSMBR® 4.5-S system shall come equipped with one (1) control panel. Each control panel provides power to the blower, the filtrate pump, and the water level floats with visual and audible alarms capable of signaling blower circuit failure and high water conditions. The control panel is equipped with SFR® (Sequencing Fixed Reactor) timed control feature. A manual silence button is included.

8. INSTALLATION AND OPERATING INSTRUCTIONS

All installation and connections work of the BioBarrier® HSMBR® 4.5 shall be done in accordance with the written instructions provided by the manufacturer and in accordance with all applicable local codes and regulations. Operations manuals shall be furnished which will include a description of installation, operation, and system maintenance procedures.

9. FLOW AND DOSING

BioBarrier® HSMBR® systems have been successfully designed, tested and certified receiving gravity, demand-based influent flow. When influent flow is controlled by pump or other means to help with highly variable flow conditions, then multiple dosing events should be used to help ensure even flow.

10. WARRANTY

Bio-Microbics, Inc. warrants all new High Strength BioBarrier® models (BioBarrier® HSMBR® 1.50 , 3.0, 4.5, 6.0, and 9.0) against defects in materials and workmanship for a period of one year after installation or 18 months from date of shipment which ever occurs first, subject to the following terms and conditions, (all other BioBarrier® system models are warranted for a period of two years after installation or three years from date of shipment, whichever occurs first, subject to the following terms and conditions):

During the warranty period, if any part is defective or fails to perform as specified when operating at design conditions, and if the equipment has been installed and is being operated and maintained in accordance with the written instructions provided by Bio-Microbics, Inc., Bio-Microbics, Inc. will repair or replace at its discretion such defective parts free of charge. Defective parts must be returned by owner to Bio-Microbics, Inc.'s factory postage paid, if so requested. The cost of labor and all other expenses resulting from replacement of the defective parts and from installation of parts furnished under this warranty and regular maintenance items such as filters or bulbs shall be borne by the owner.

This warranty does not cover general system misuse, aerator components which have been damaged by flooding or any components that have been disassembled by unauthorized persons, improperly installed or damaged due to altered or improper wiring or overload protection. This warranty applies only to the treatment plant and does not include any of the structure wiring, plumbing, drainage, septic tank or disposal system. Bio-Microbics, Inc. reserves the right to revise, change or modify the construction and/or design of the BioBarrier® HSMBR® system, or any component part or parts thereof, without incurring any obligation to make such changes or modifications in present equipment. Bio-Microbics, Inc. is not responsible for consequential or incidental damages of any nature resulting from such things as, but not limited to, defect in design, material, or workmanship, or delays in delivery, replacements or repairs.

THIS WARRANTY IS IN LIEU OF ALL OTHER WARRANTIES EXPRESS OR IMPLIED. BIO-MICROBICS SPECIFICALLY DISCLAIMS ANY IMPLIED WARRANTY OF MERCHANTABILITY OR FITNESS FOR A PARTICULAR PURPOSE. NO REPRESENTATIVE OR PERSON IS AUTHORIZED TO GIVE ANY OTHER WARRANTY OR TO ASSUME FOR BIO-MICROBICS, INC., ANY OTHER LIABILITY IN CONNECTION WITH THE SALE OF ITS PRODUCTS. Contact your local distributor for parts and service.

DO NOT SCALE
UNLESS NOTED
DIMENSIONS
ARE IN INCHES
[CENTIMETERS]
TOLERANCES
± 0.02 IN/IN
[± 0.05 CM/CM]



HSMBR 4.5

THE INFORMATION CONTAINED IN THIS DRAWING IS THE SOLE PROPERTY OF BIO-MICROBICS INC. ANY REPRODUCTION IN PART OR AS A WHOLE WITHOUT THE WRITTEN PERMISSION OF BIO-MICROBICS INC. IS PROHIBITED. DESIGN AND INVENTION RIGHTS ARE RESERVED. IN THE INTEREST OF TECHNOLOGICAL ADVANCEMENT, ALL PRODUCTS ARE SUBJECT TO DESIGN AND OR MATERIAL CHANGE WITHOUT NOTICE.

BIO-MICROBICS © 2016

WEIGHT		lb	SIZE	DRAWING NUMBER		SHEET 6 OF 6
NAME	DATE		A	Specifications HSMBR 4.5		
DRAWN	11/25/2009			REVISED 10/12/2015	REV.	
CHECKED	PF	10/12/2015				