

SECTION A-A  
SCALE 1 : 45

NOTES

1. Blower piping to BioBarrier® MBR® may not exceed 40 FT [12 m] total length and use 4 elbows maximum per train. For distances greater than 40 FT [12 m] - consult factory. Blowers must be located above flood/standing water levels on concrete bases 26" X 20" X2" [65 X 50 X 5cm] minimum.
2. Run vent(s) to desired location above finish grade and cover opening(s) with vent grate(s) w/at least 12 sq in. [77 sq. cm] of total open surface area. Secure with stainless steel screws. Vent piping must not allow excess moisture build up or back pressure.
3. All appurtenances to BioBarrier® (e.g. tank pump outs, etc.) must conform to all country, state, province, and local plumbing and electrical codes.
4. The BioBarrier® MBR® control systems are provided by Bio-Microbics, Inc.
5. The primary compartments may be a separate tank.
6. The baffle separating the settling and the treatment chambers shall be sealed to the top of the tank, as shown on the drawing. Ventilation for the settling zone shall be provided for in the same manner as a traditional septic tank.
7. All inspection, viewing, access, and pump out ports must be secured, to prevent accidental or unauthorized access.
8. Tank, anchors, piping, conduit, blower housing pads and vents are provided by others.
9. All piping and ancillary equipment installed after BioBarrier® MBR® , must not impede or restrict filtrate pump.
10. BioBarrier® MBR® assemblies must be secured to the tanks to prevent movement or floatation(see Installation Instructions for details).
11. If less than any of the specified minimums is considered necessary, consult factory for guidance.

DO NOT SCALE  
UNLESS NOTED  
DIMENSIONS  
ARE IN INCHES  
[CENTIMETERS]  
TOLERANCES  
± 0.02 IN/IN  
[± 0.05 CM/CM]



MBR 1.0

WEIGHT		lb	SIZE	DRAWING NUMBER		SHEET 1 OF 6
NAME	DATE		A	MBR® 1.0		
DRAWN	CTC	11/25/2009		REVISED 6/18/2015		
CHECKED	PF	6/18/2015		REV. INI-05-B		

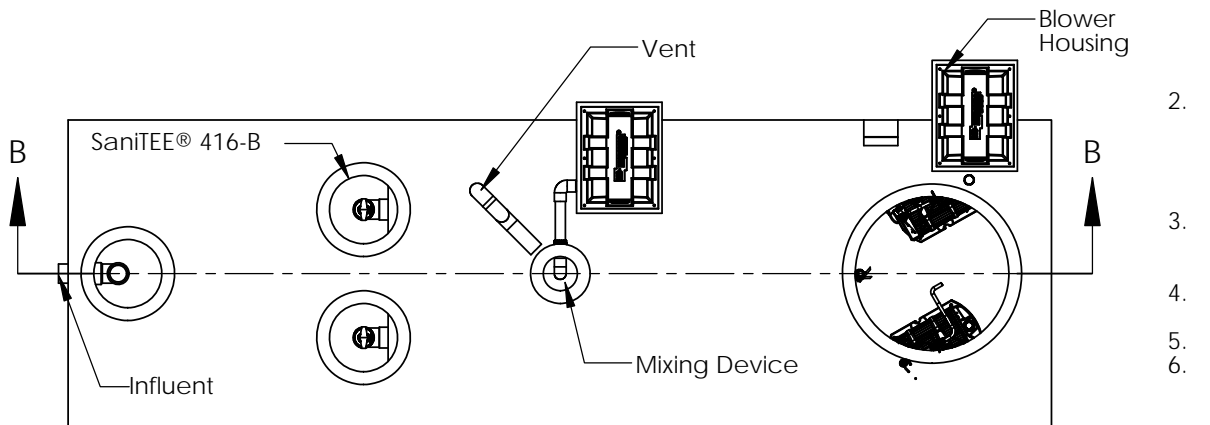

Settling Zone  
700 Gallon MIN  
[2650 L MIN]

Treatment Zone  
Anoxic Zone  
1500 Gallons  
[5700L]

Aerobic Zone  
1500 Gallons  
[5700L]

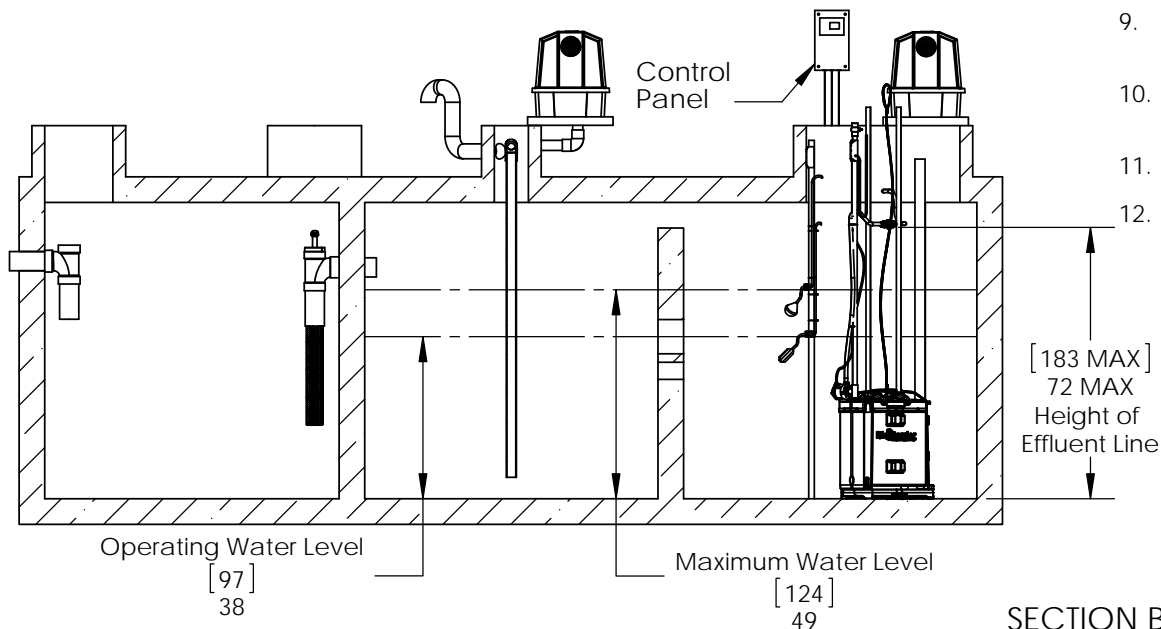

**NOTES**

- Blower piping to BioBarrier® MBR® may not exceed 40 FT [12 m] total length and use 4 elbows maximum per train. For distances greater than 40 FT [12 m] - consult factory. Blowers must be located above flood/standing water levels on concrete bases 26" X 20" X2" [65 X 50 X 5cm] minimum.
- Run vent(s) to desired location above finish grade and cover opening(s) with vent grate(s) w/at least 12 sq in. [77 sq. cm] of total open surface area. Secure with stainless steel screws. Vent piping must not allow excess moisture build up or back pressure.
- All appurtenances to BioBarrier® (e.g. tank pump outs, etc.) must conform to all country, state, province, and local plumbing and electrical codes.
- The BioBarrier® MBR® control systems are provided by Bio-Microbics, Inc.
- The primary compartments may be a separate tank.
- The baffle separating the settling and the treatment chambers shall be sealed to the top of the tank, as shown on the drawing. Ventilation for the settling zone shall be provided for in the same manner as a traditional septic tank.
- All inspection, viewing, access, and pump out ports must be secured, to prevent accidental or unauthorized access.
- Tank, anchors, piping, conduit, blower housing pads and vents are provided by others.
- All piping and ancillary equipment installed after BioBarrier® MBR®, must not impede or restrict filtrate pump.
- BioBarrier® MBR® assemblies must be secured to the tanks to prevent movement or floatation(see Installation Instructions for details).
- If less than any of the specified minimums is considered necessary, consult factory for guidance.
- For enhanced nitrogen removal.
  - Anoxic Zone
    - Baffle wall should evenly distribute the volume in the Treatment Zone between the anoxic and aerobic zone.
    - Mixing device is required.

DO NOT SCALE		 BETTER WATER. BETTER WORLD.®		MBR 1.0	
UNLESS NOTED DIMENSIONS ARE IN INCHES [CENTIMETERS] TOLERANCES ± 0.02 IN/IN [± 0.05 CM/CM]					
WEIGHT	lb	SIZE	DRAWING NUMBER		SHEET 2 OF 6
		A	MBR® 1.0-N		
DRAWN	CTC	DATE	REVISED 6/18/2015		
CHECKED	PF	6/18/2015	REV. INI-04-R		

THE INFORMATION CONTAINED IN THIS DRAWING IS THE SOLE PROPERTY OF BIO-MICROBICS INC. ANY REPRODUCTION IN PART OR AS A WHOLE WITHOUT THE WRITTEN PERMISSION OF BIO-MICROBICS INC. IS PROHIBITED. DESIGN AND INVENTION RIGHTS ARE RESERVED. IN THE INTEREST OF TECHNOLOGICAL ADVANCEMENT, ALL PRODUCTS ARE SUBJECT TO DESIGN AND OR MATERIAL CHANGE WITHOUT NOTICE.

BIO-MICROBICS © 2015

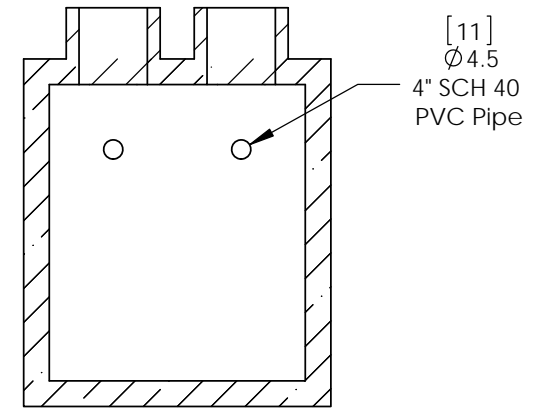
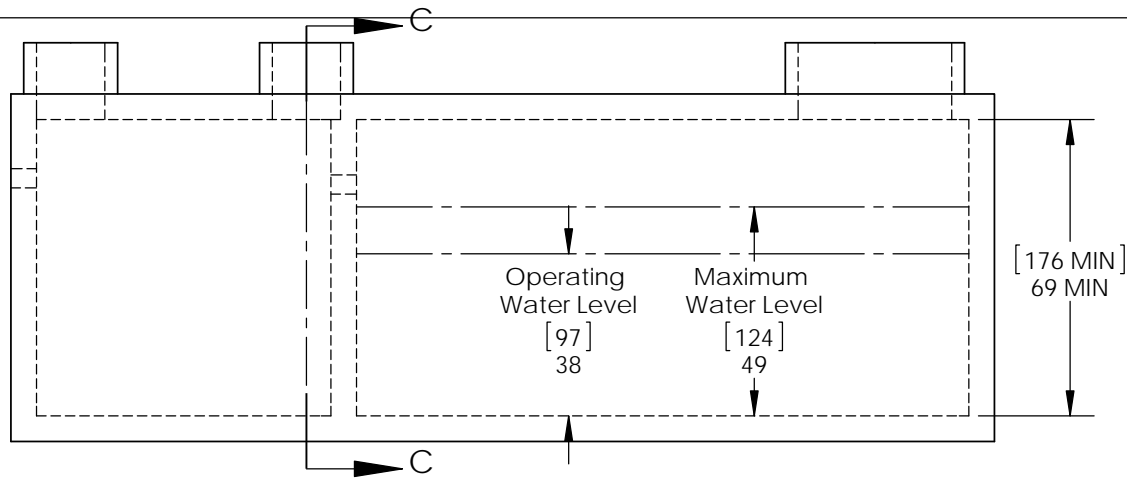

SECTION C-C

Settling Zone  
700 Gallon MIN  
[2650 L MIN]

Treatment Zone  
3000 Gallons  
[11400L]

[91 MIN]  
Ø36 MIN  
MBR Access

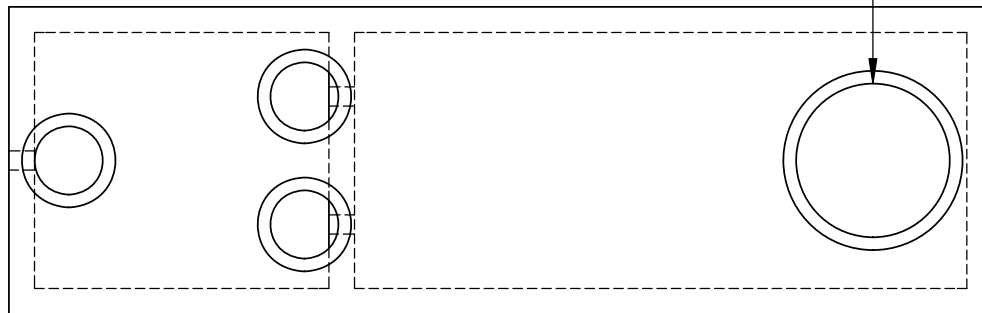

NOTES

1. All appurtenances to BioBarrier® (e.g. tank pump outs, etc.) must conform to all country, state, province, and local plumbing and electrical codes.
2. The primary compartment may be a separate tank.
3. The baffle separating the settling and treatment chambers shall extend to the top of the tank locating discharge port above the Maximum water level as shown on the drawing. Ventilation for the settling zone shall be provided through a house vent line or a vent in the tank itself.
4. All inspection, viewing, access, and pump out ports must be secured, to prevent accidental or unauthorized access.
5. Tank, anchors, piping, conduit, blower concrete base and vents are provided by others.
6. All piping and ancillary equipment installed after BioBarrier®, must not impede or restrict free flow of effluent.
7. BioBarrier® module must be secured to the tank to prevent movement or floatation (See installation manual).
8. Min Volume is determined based on the frequency of sludge wasting. For a reduced pump out schedule, tank volume should be increased, consult factory for guidance.
9. If less than any of the specified minimums is considered necessary, consult factory for guidance.

DO NOT SCALE  
UNLESS NOTED  
DIMENSIONS  
ARE IN INCHES  
[CENTIMETERS]  
TOLERANCES  
± 0.02 IN/IN  
[± 0.05 CM/CM]



MBR 1.0

WEIGHT		lb	SIZE	DRAWING NUMBER		SHEET 3 OF 6
NAME	DATE		A	Tank Details MBR 1.0		
DRAWN	CTC	11/25/2009		REVISED 6/18/2015	REV. INI-04-X	
CHECKED	PF	6/18/2015				

THE INFORMATION CONTAINED IN THIS DRAWING IS THE SOLE PROPERTY OF BIO-MICROBICS INC. ANY REPRODUCTION IN PART OR AS A WHOLE WITHOUT THE WRITTEN PERMISSION OF BIO-MICROBICS INC. IS PROHIBITED. DESIGN AND INVENTION RIGHTS ARE RESERVED. IN THE INTEREST OF TECHNOLOGICAL ADVANCEMENT, ALL PRODUCTS ARE SUBJECT TO DESIGN AND OR MATERIAL CHANGE WITHOUT NOTICE.

BIO-MICROBICS © 2015

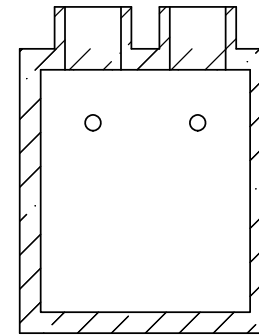
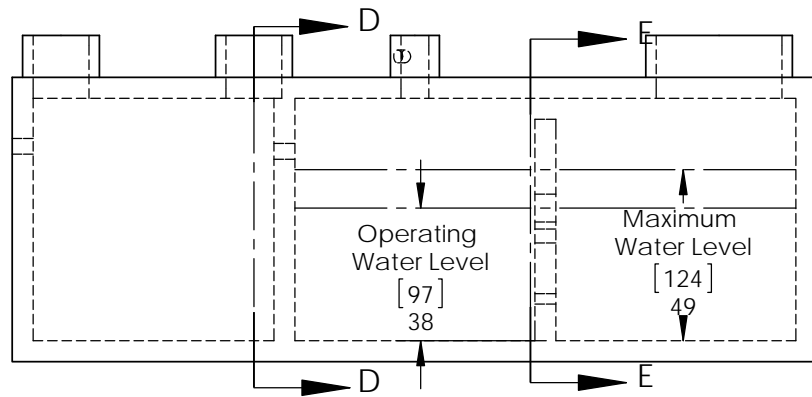

SECTION D-D

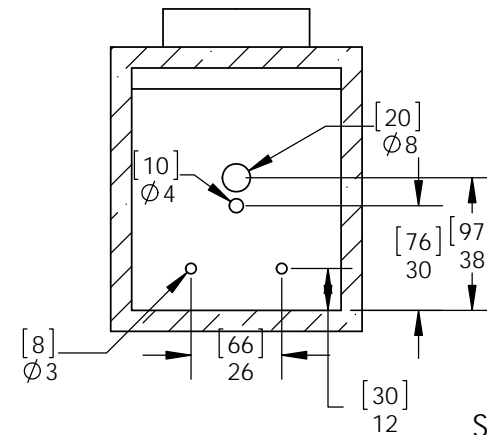
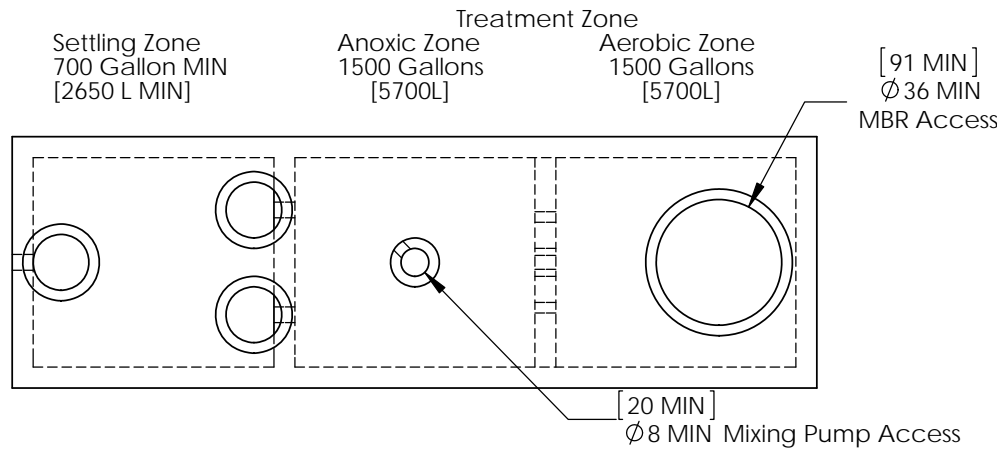

SECTION E-E

NOTES

1. All appurtenances to BioBarrier® (e.g. tank pump outs, etc.) must conform to all country, state, province, and local plumbing and electrical codes.
2. The primary compartment may be a separate tank.
3. The baffle separating the settling and treatment chambers shall extend to the top of the tank locating discharge port above the Maximum water level as shown on the drawing. Ventilation for the settling zone shall be provided through a house vent line or a vent in the tank itself.
4. All inspection, viewing, access, and pump out ports must be secured, to prevent accidental or unauthorized access.
5. Tank, anchors, piping, conduit, blower concrete base and vents are provided by others.
6. All piping and ancillary equipment installed after BioBarrier®, must not impede or restrict free flow of effluent.
7. BioBarrier® module must be secured to the tank to prevent movement or floatation (See installation manual).
8. Min Volume is determined based on the frequency of sludge wasting. For a reduced pump out schedule, tank volume should be increased, consult factory for guidance.
9. If less than any of the specified minimums is considered necessary, consult factory for guidance.
10. For enhanced nitrogen removal.
  - Anoxic Zone
  - Baffle wall should evenly distribute the volume in the Treatment Zone between the anoxic and aerobic zone.
  - Mixing device is required.

<p><b>DO NOT SCALE</b></p> <p>UNLESS NOTED DIMENSIONS ARE IN INCHES [CENTIMETERS]</p> <p>TOLERANCES ± 0.02 IN/IN [± 0.05 CM/CM]</p>		<p>MBR 1.0</p>	
WEIGHT	lb	SIZE	DRAWING NUMBER
		A	Tank Details MBR 1.0-N
DRAWN	CTC	DATE	11/25/2009
CHECKED	PF	DATE	6/18/2015
		REVISED	6/18/2015
		REV.	INI-04-X

THE INFORMATION CONTAINED IN THIS DRAWING IS THE SOLE PROPERTY OF BIO-MICROBICS INC. ANY REPRODUCTION IN PART OR AS A WHOLE WITHOUT THE WRITTEN PERMISSION OF BIO-MICROBICS INC. IS PROHIBITED. DESIGN AND INVENTION RIGHTS ARE RESERVED. IN THE INTEREST OF TECHNOLOGICAL ADVANCEMENT, ALL PRODUCTS ARE SUBJECT TO DESIGN AND OR MATERIAL CHANGE WITHOUT NOTICE.

BIO-MICROBICS © 2015

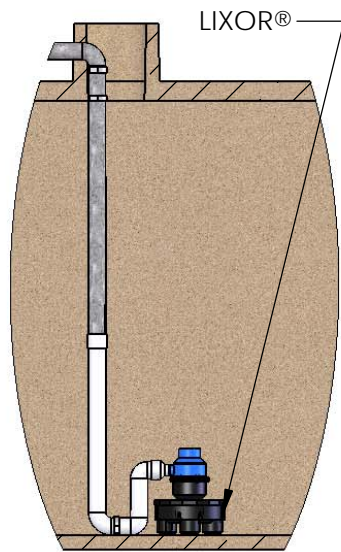

### Supplemental Air

see note 4,5, & 6

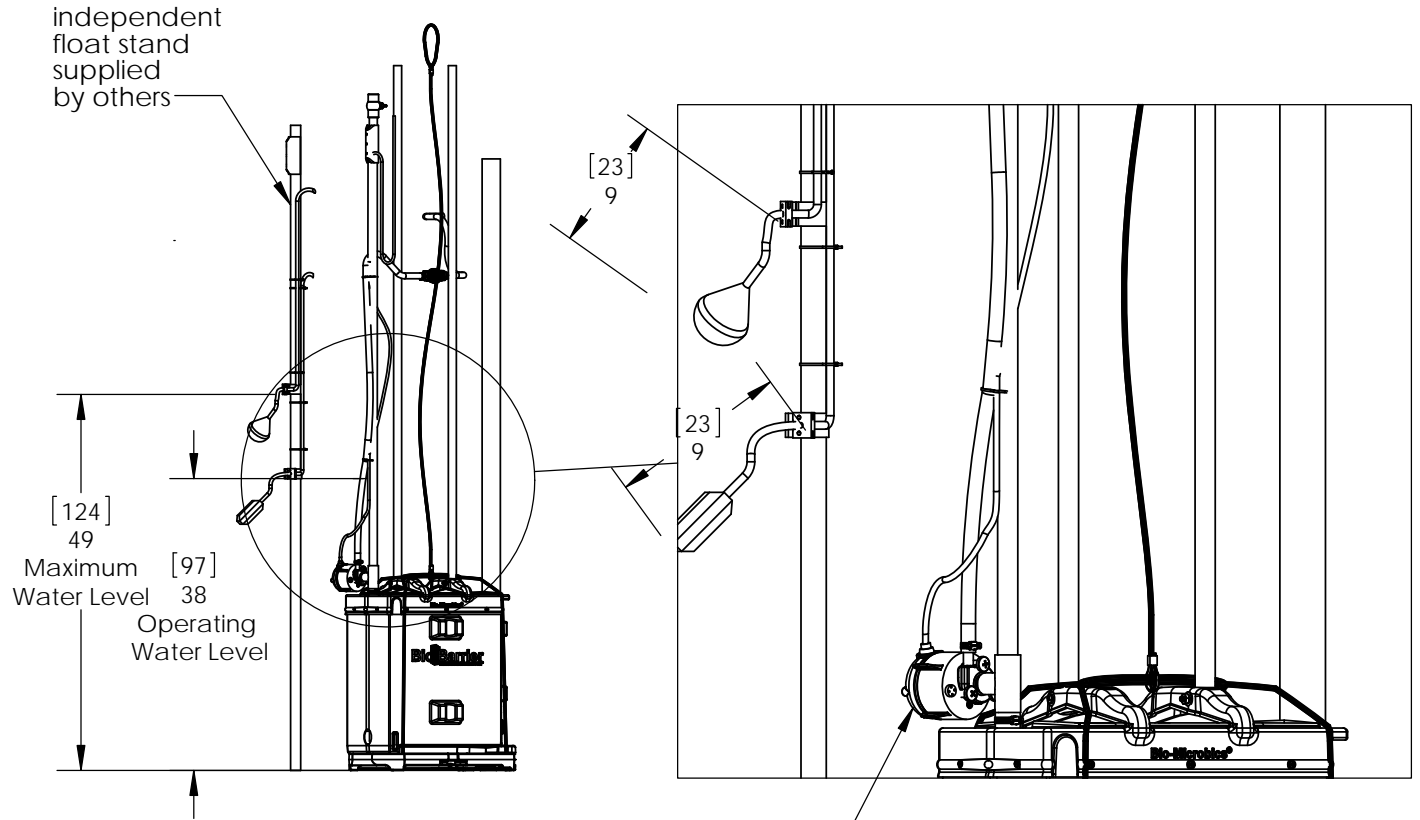

#### Notes:

1. Filtrate Pump must be secured in a dry vault and not be exposed to freezing temperatures.
2. Float stand should be located away from the MBR modules within the treatment zone to prevent float chatter.
3. Utilize SS lifting cable to remove the MBR module.
4. Supplemental aeration with LIXOR® will be required for wastewater with higher than 300mg/L BOD.
5. See LIXOR® Drawings for more details.
6. Provide additional ventilation as required per LIXOR specifications.

DO NOT SCALE  
UNLESS NOTED  
DIMENSIONS  
ARE IN INCHES  
[CENTIMETERS]  
TOLERANCES  
± 0.02 IN/IN  
[± 0.05 CM/CM]



MBR 1.0

THE INFORMATION CONTAINED IN THIS DRAWING IS THE SOLE PROPERTY OF BIO-MICROBICS INC. ANY REPRODUCTION IN PART OR AS A WHOLE WITHOUT THE WRITTEN PERMISSION OF BIO-MICROBICS INC. IS PROHIBITED. DESIGN AND INVENTION RIGHTS ARE RESERVED. IN THE INTEREST OF TECHNOLOGICAL ADVANCEMENT, ALL PRODUCTS ARE SUBJECT TO DESIGN AND OR MATERIAL CHANGE WITHOUT NOTICE.

BIO-MICROBICS © 2015

WEIGHT	lb	SIZE	DRAWING NUMBER	SHEET 5 OF 6
NAME	DATE	A	MBR® Details	
DRAWN	CTC 11/25/2009			
CHECKED	PF 6/18/2015	REVISED 6/18/2015	REV. INI-05-B	

Specifications for BioBarrier® MBR® 1.0 Wastewater Treatment System

1. GENERAL

The contractor shall furnish and install (1) BioBarrier® MBR® 1.0 treatment system as manufactured by Bio-Microbics, Inc. The treatment system shall be complete with all needed equipment as shown on the drawings and specified herein. The principal items of equipment supplied by Bio-Microbics, Inc. shall include two (2) BioBarrier® MBR® assemblies, all controls, filtrate pumps, air blower assemblies, mixing device if applicable and a SaniTEE® 818-B pre-screen device. The BioBarrier® MBR 1.0-N system shall be supplied with a mixing device provided by Bio-Microbics. All other items will be provided by others. The BioBarrier® 1.00 unit shall be situated within a 3,000 Gallon [11,400 L] minimum single compartment tank or in a 3700 gallon [14,000L] minimum multiple compartment tank with or without the optional mixing device. Suggested Maximum settling zone is (1) X the daily flow. Tank(s) must provide adequate pump out access and conform to local, state, and all other applicable codes. The contractor shall provide coordination with tank supplier with regards to fabrication of the tank, installation of the BioBarrier® unit and delivery to the job site.

2. OPERATING CONDITIONS

The BioBarrier® MBR® 1.0 treatment system shall be capable of treating up to 1,000 gpd wastewater from all facilities producing appropriate waste to develop and sustain a viable biomass. Waste containing inhibitory substances for the biological processes or membrane filtration operation is not recommended for treatment in the BioBarrier® MBR® system. Consult factory for proper sizing and usage.

3. MEMBRANE

The membrane is a combination of ultrafiltration and microfiltration using PVdF and PES cast material. The membrane sheet is supported by HDPE or ABS and laser welded to the plate. The BioBarrier® MBR® membrane module shall consist of flat sheet membranes arranged in a cartridge which is aerated via subhousing air grid. The BioBarrier® MBR® membrane assembly shall be fixed in position and shall use non corrosive parts. The membrane system shall be designed and installed to ensure that adequate turbulence is provided by the aeration system to insure easy movement of MLSS within the membrane system.

4. BLOWER

The BioBarrier® MBR® 1.0 system shall come equipped with a one (1) blower capable of delivering 10-40 CFM [20-60 m3/hr]. The blower assembly shall include an inlet filter with metal filter element. Blowers shall be mounted, up to 40 feet [12 meters] maximum, from the BioBarrier® MBR® assembly on a contractor supplied concrete base. Blowers must not set in standing water and their elevation must be higher than the normal flood level. A two-piece, rectangular housing shall be provided. The discharge air line from each blower to the BioBarrier® MBR® assembly shall be provided and installed by the contractor.

5. SUBMERSIBLE FILTRATE PUMP

The submersible pump must be secured to the MBR housing to prevent damage to the treatment system. The discharge line must not exceed four feet above the pump during operations. The installation downstream of the Bio-Microbics supplied effluent line must not create any backpressure on the pump. The submersible pump is not intended as dosing pump for final disposal of the effluent.

6. ELECTRICAL

The electrical source should be within 150 feet [45.7 meters] of the blower pre consult local codes for longer wiring distances. All wiring must conform to all applicable codes (IEC, NEC, etc.). Wiring distances must prevent significant voltage loss. Input power on 60Hz electrical system is 110/220 VAC, single phase, 15/20 Amps. Input power on 50Hz electrical systems 127/230 VAC, single phase 15/20 Amps. All conduit and wiring shall be supplied by contractor.

7. CONTROLS

The BioBarrier® MBR® 1.0 system shall come equipped with one (1) control panel. The control panel provides power to the blower, the filtrate pump, the optional mixing device, and the water level floats with visual and audible alarms capable of signaling blower circuit failure and high water conditions. The control panel is equipped with SFR® (Sequencing Fixed Reactor) timed control feature. A manual silence button is included.

8. INSTALLATION AND OPERATING INSTRUCTIONS

All installation and connections work of the BioBarrier® MBR® 1.0 shall be done in accordance with the written instructions provided by the manufacturer and in accordance with all applicable local codes and regulations. Operations manuals shall be furnished which will include a description of installation, operation, and system maintenance procedures.

9. FLOW AND DOSING

BioBarrier® MBR® systems have been successfully designed, tested and certified receiving gravity, demand-based influent flow. When influent flow is controlled by pump or other means to help with highly variable flow conditions, then multiple dosing events should be used to help ensure even flow.

10. WARRANTY

Bio-Microbics, Inc. warrants all new residential BioBarrier® models (BioBarrier® 0.50, 1.0, and 1.5) against defects in materials and workmanship for a period of two years after installation or three years from date of shipment which ever occurs first, subject to the following terms and conditions, (all other BioBarrier® system models are warranted for a period of one year after installation or eighteen months from date of shipment, whichever occurs first, subject to the following terms and conditions):

During the warranty period, if any part is defective or fails to perform as specified when operating at design conditions, and if the equipment has been installed and is being operated and maintained in accordance with the written instructions provided by Bio-Microbics, Inc., Bio-Microbics, Inc. will repair or replace at its discretion such defective parts free of charge. Defective parts must be returned by owner to Bio-Microbics, Inc.'s factory postage paid, if so requested. The cost of labor and all other expenses resulting from replacement of the defective parts and from installation of parts furnished under this warranty and regular maintenance items such as filters or bulbs shall be borne by the owner. This warranty does not cover general system misuse, aerator components which have been damaged by flooding or any components that have been disassembled by unauthorized persons, improperly installed or damaged due to altered or improper wiring or overload protection. This warranty applies only to the treatment plant and does not include any of the structure wiring, plumbing, drainage, septic tank or disposal system. Bio-Microbics, Inc. reserves the right to revise, change or modify the construction and/or design of the BioBarrier system, or any component part or parts thereof, without incurring any obligation to make such changes or modifications in present equipment. Bio-Microbics, Inc. is not responsible for consequential or incidental damages of any nature resulting from such things as, but not limited to, defect in design, material, or workmanship, or delays in delivery, replacements or repairs.

THIS WARRANTY IS IN LIEU OF ALL OTHER WARRANTIES EXPRESS OR IMPLIED. BIO-MICROBICS SPECIFICALLY DISCLAIMS ANY IMPLIED WARRANTY OF MERCHANTABILITY OR FITNESS FOR A PARTICULAR PURPOSE. NO REPRESENTATIVE OR PERSON IS AUTHORIZED TO GIVE ANY OTHER WARRANTY OR TO ASSUME FOR BIO-MICROBICS, INC., ANY OTHER LIABILITY IN CONNECTION WITH THE SALE OF ITS PRODUCTS. Contact your local distributor for parts and service.

DO NOT SCALE			MBR 1.0	
UNLESS NOTED DIMENSIONS ARE IN INCHES [CENTIMETERS] TOLERANCES ± 0.02 IN/IN [± 0.05 CM/CM]				
WEIGHT	lb	SIZE	DRAWING NUMBER	
		A	Specifications MBR 1.0	
DRAWN	11/25/2009	CHECKED	PF	6/18/2015
REVISED 6/18/2015		REV.		

THE INFORMATION CONTAINED IN THIS DRAWING IS THE SOLE PROPERTY OF BIO-MICROBICS INC. ANY REPRODUCTION IN PART OR AS A WHOLE WITHOUT THE WRITTEN PERMISSION OF BIO-MICROBICS INC. IS PROHIBITED. DESIGN AND INVENTION RIGHTS ARE RESERVED. IN THE INTEREST OF TECHNOLOGICAL ADVANCEMENT, ALL PRODUCTS ARE SUBJECT TO DESIGN AND OR MATERIAL CHANGE WITHOUT NOTICE.

BIO-MICROBICS © 2015

SHEET 6 OF 6